

REV	DESCRIPTION	DWN	CHKR	APV	DATE
1					

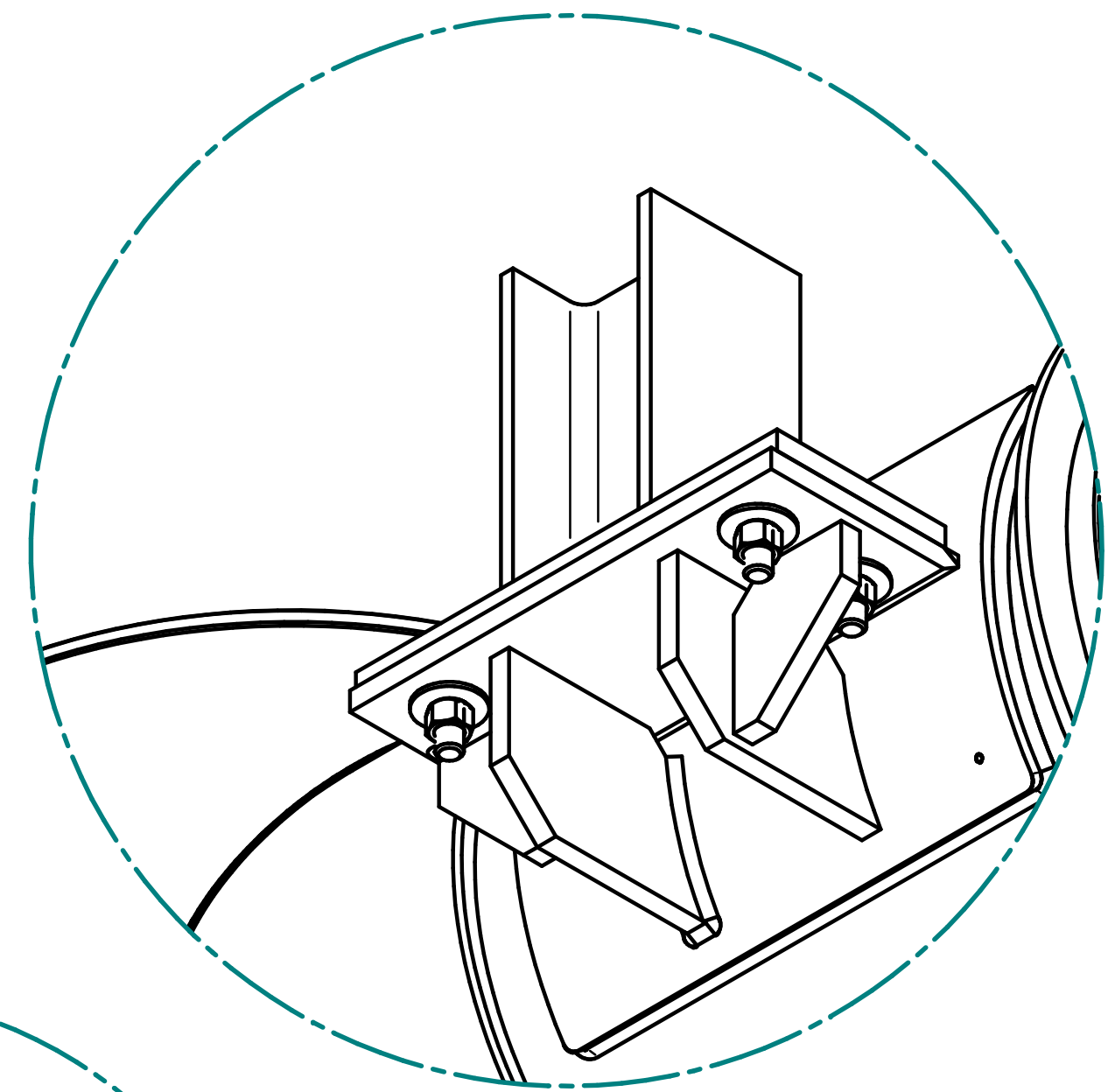

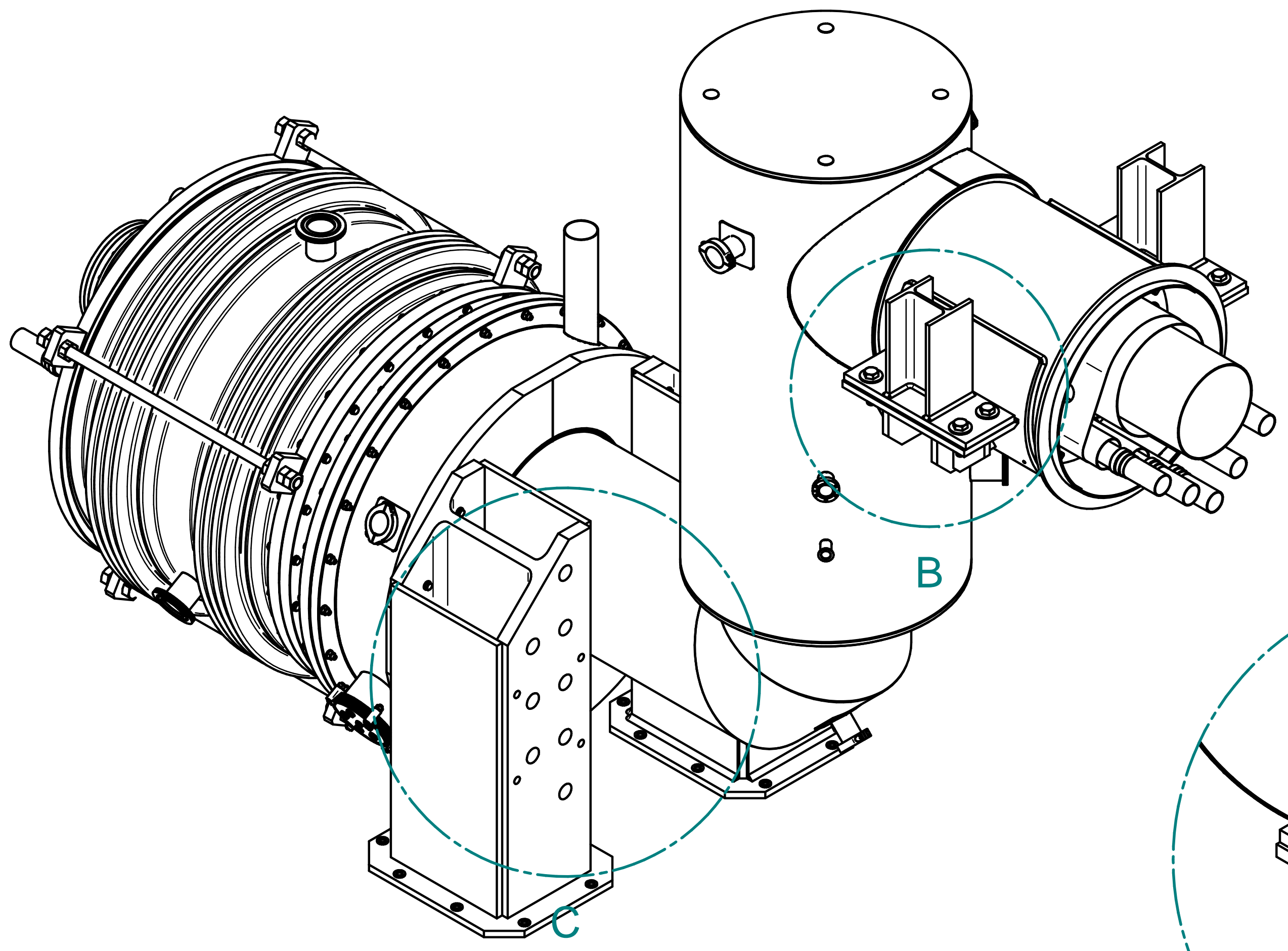

DETAIL D

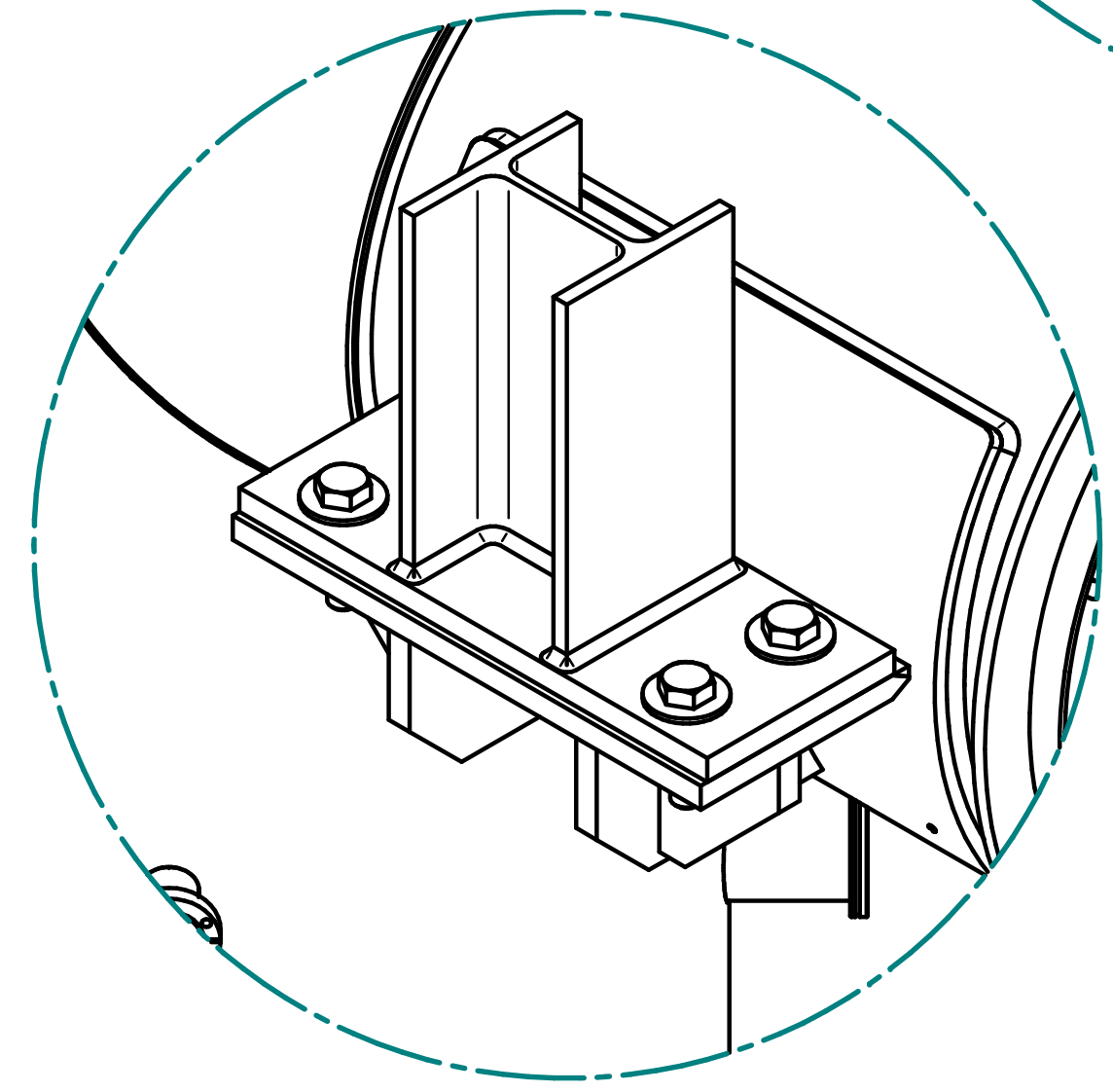

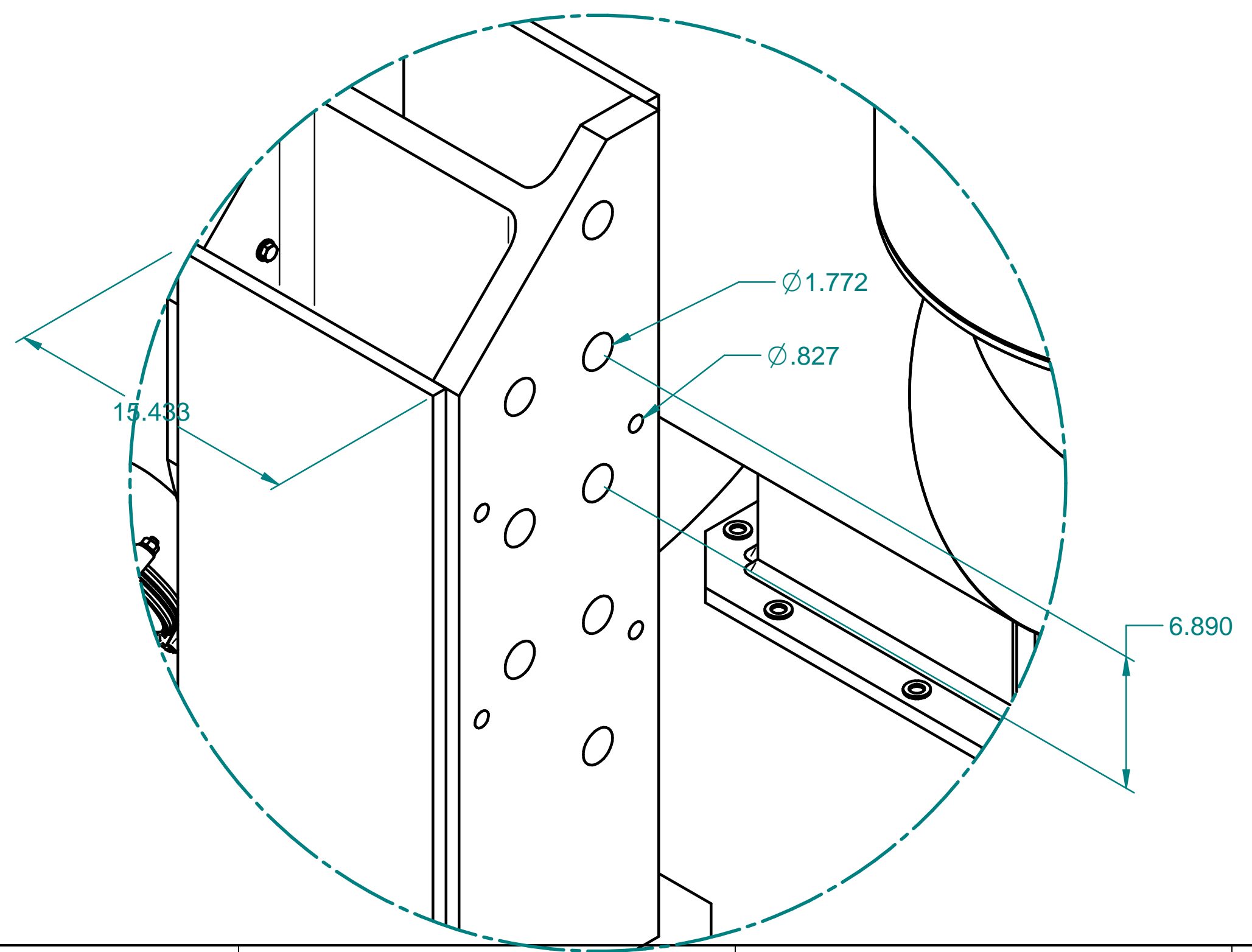
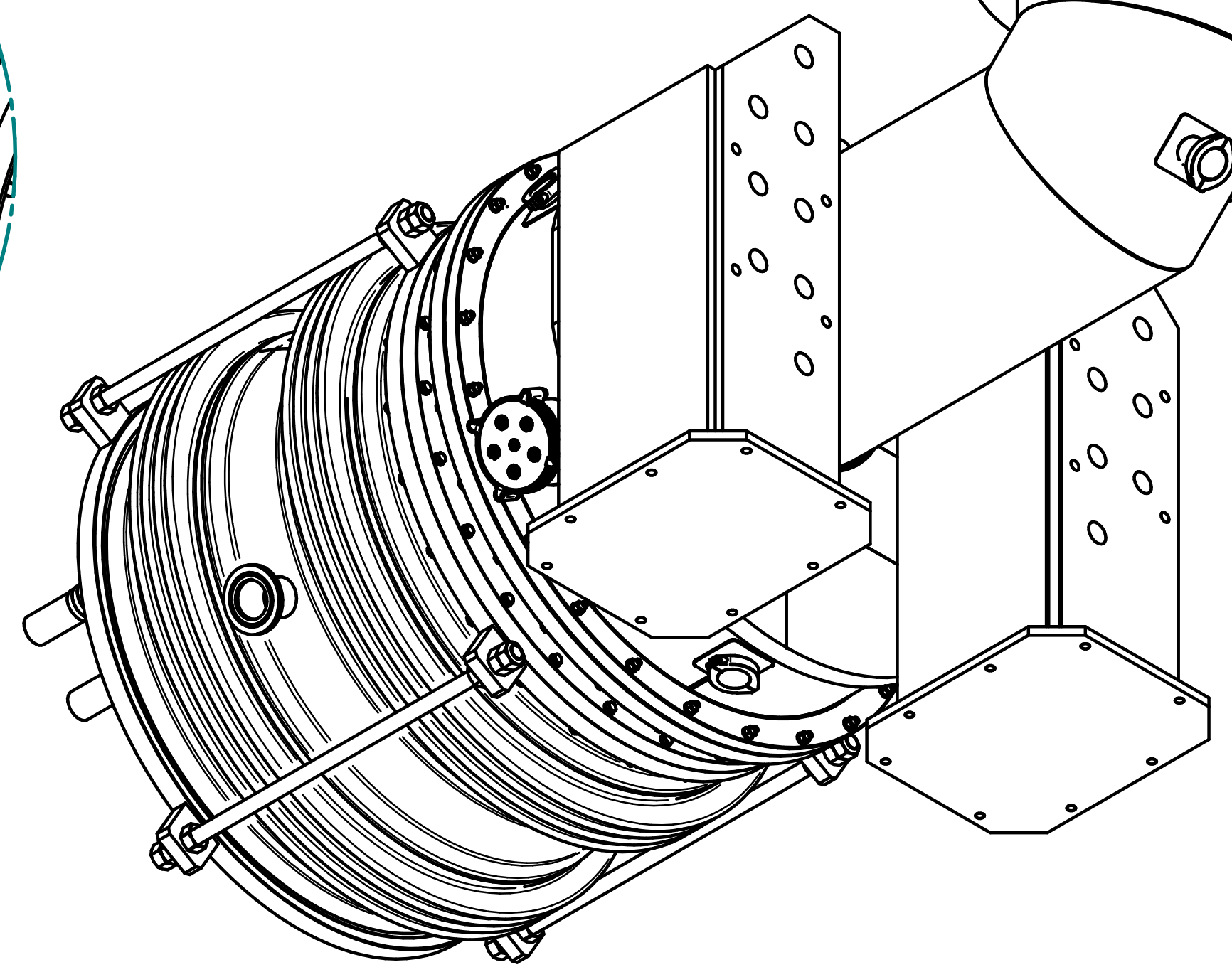
DETAIL B

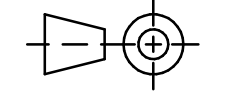

DETAIL C

DIMENSIONING AND TOLERANCING IS IN ACCORDANCE WITH ASME Y14.5-2009		SCALE: DO NOT SCALE DRAWING	ESTIMATED MASS:	CAD FILE NAME:																
UNLESS OTHERWISE SPECIFIED DIMENSIONS ARE IN MILLIMETERS		 																		
TOLERANCES: BREAK EDGES 0.13 - 0.4 INTERNAL CORNERS R 0.4 MAX																				
ANGLE \pm ALL SURF \checkmark 		THE DRAWINGS, SPECIFICATIONS AND OTHER DATA HEREIN PROVIDED SHALL NOT BE COPIED, PUBLISHED OR OTHERWISE FURTHER DISSEMINATED WITHOUT PRIOR WRITTEN PERMISSION OF STANFORD UNIVERSITY/SLAC																		
NEXT ASSEMBLIES:		ENGR: _____	DATE: _____																	
<table border="1"> <tr> <th>DIMENSIONS</th> <th>< 6</th> <th>> 6</th> <th>> 30</th> <th>> 120</th> <th>> 315</th> <th>> 1000</th> <th>> 2000</th> </tr> <tr> <td>GENERAL TOLERANCES</td> <td>± 0.1</td> <td>± 0.2</td> <td>± 0.3</td> <td>± 0.5</td> <td>± 0.8</td> <td>± 1.2</td> <td>± 2</td> </tr> </table>		DIMENSIONS	< 6	> 6	> 30	> 120	> 315	> 1000	> 2000	GENERAL TOLERANCES	± 0.1	± 0.2	± 0.3	± 0.5	± 0.8	± 1.2	± 2	DWN: _____	APPROVALS: _____	
DIMENSIONS	< 6	> 6	> 30	> 120	> 315	> 1000	> 2000													
GENERAL TOLERANCES	± 0.1	± 0.2	± 0.3	± 0.5	± 0.8	± 1.2	± 2													
		CHKR: _____	DRAWING NUMBER: _____																	
			REVISION NUMBER: _____																	