

4

3

2

1

REV	DESCRIPTION	DWN	CHKR	APVD	DATE
-----	-------------	-----	------	------	------

D

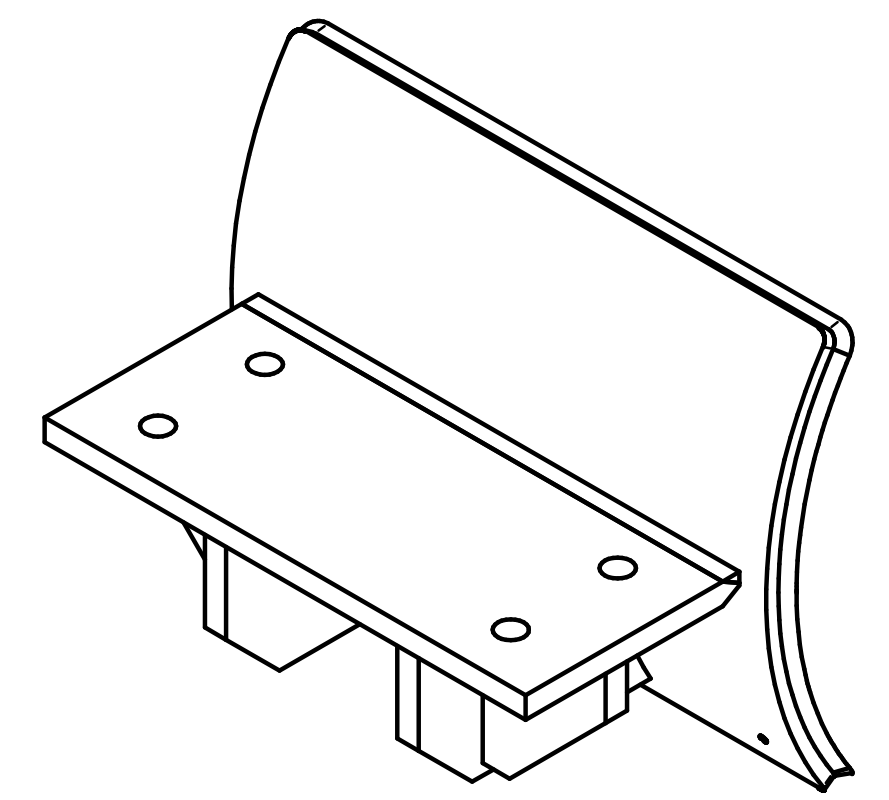
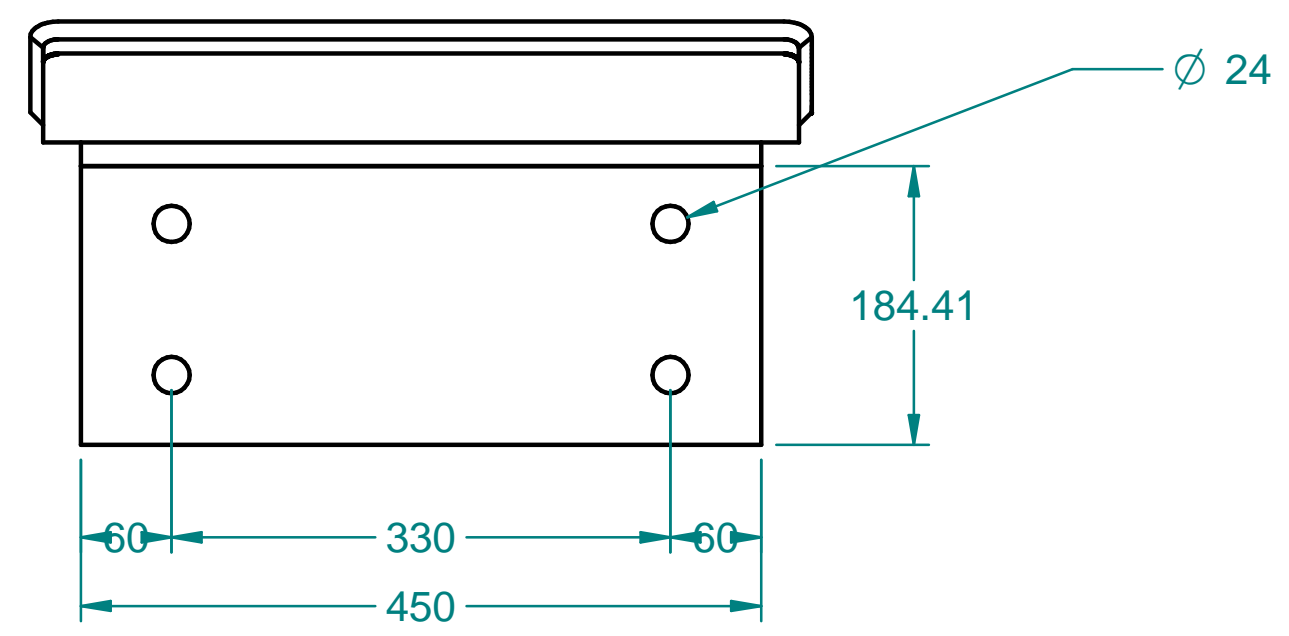

C

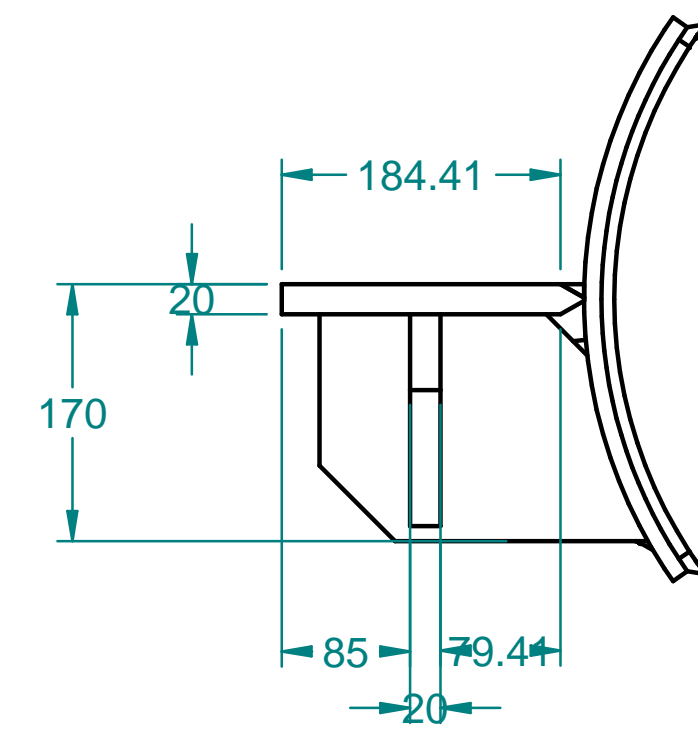
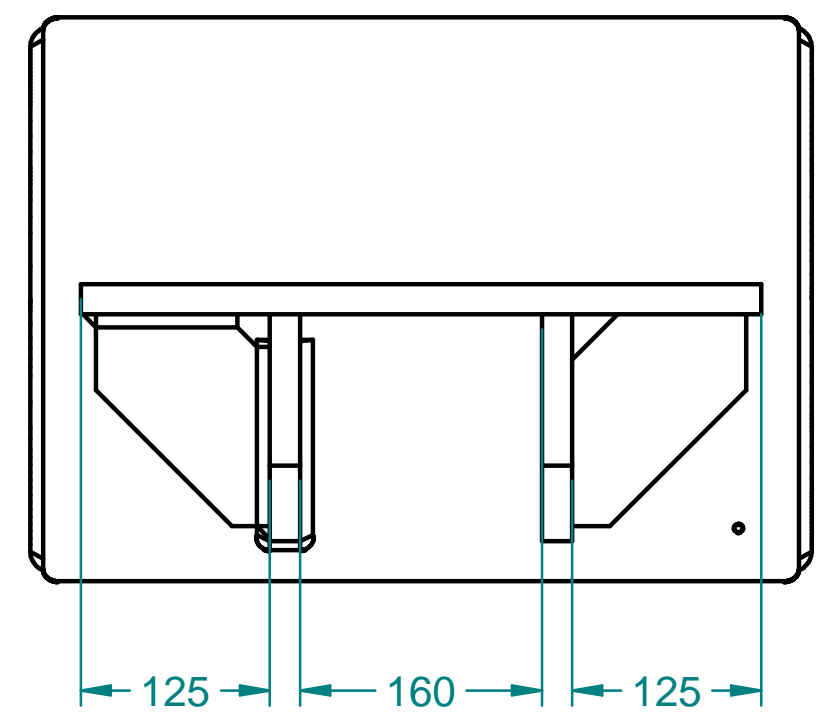

B

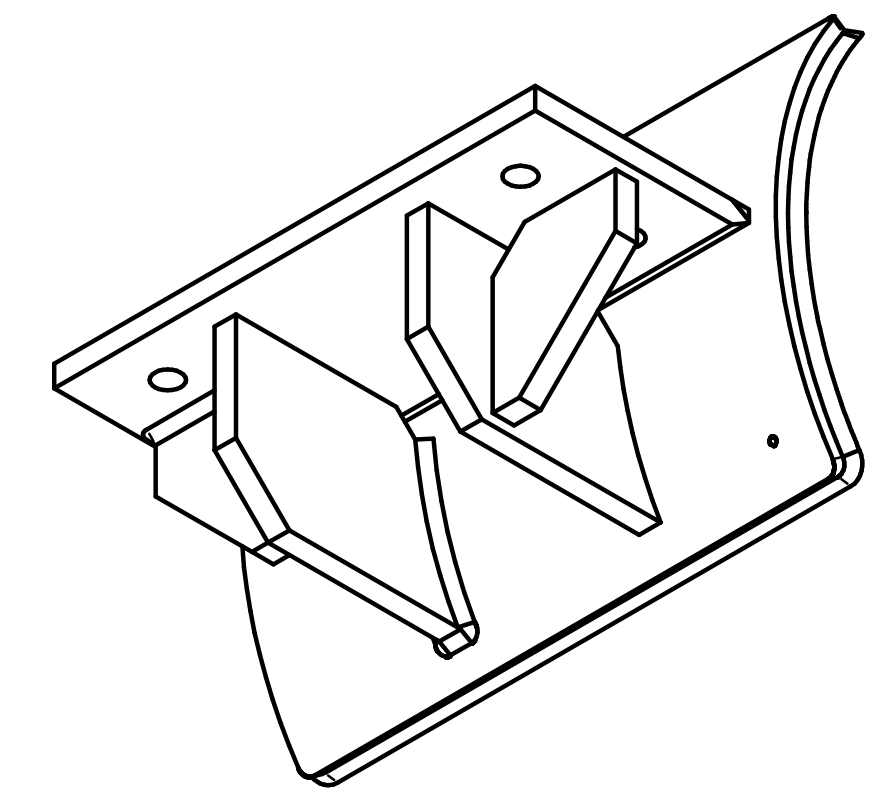
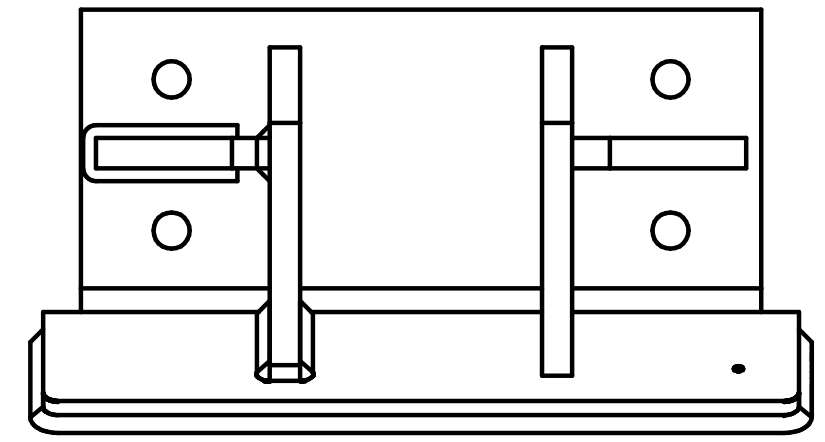

A

NEXT ASSEMBLIES:	DIMENSIONING AND TOLERANCING IS IAW ASME Y14.5-2009		SCALE: DO NOT SCALE DRAWING	ESTIMATED MASS:	CAD FILE NAME:																
	UNLESS OTHERWISE SPECIFIED DIMENSIONS ARE IN MILLIMETERS			THE DRAWINGS, SPECIFICATIONS AND OTHER DATA HEREIN PROVIDED SHALL NOT BE COPIED, PUBLISHED OR OTHERWISE FURTHER DISSEMINATED WITHOUT PRIOR WRITTEN PERMISSION OF STANFORD UNIVERSITY/SLAC																	
	TOLERANCES: BREAK EDGES 0.13 - 0.4 INTERNAL CORNERS R 0.4 MAX																				
	ANGLE $\pm$ ALL SURF $\checkmark$		ENGR _____ DATE _____	APPROVALS																	
<table border="1"> <tr> <td>DIMENSIONS</td> <td>&lt; 6</td> <td>&gt; 6</td> <td>&gt; 30</td> <td>&gt; 120</td> <td>&gt; 315</td> <td>&gt; 1000</td> <td>&gt; 2000</td> </tr> <tr> <td>GENERAL TOLERANCES</td> <td><math>\pm 0.1</math></td> <td><math>\pm 0.2</math></td> <td><math>\pm 0.3</math></td> <td><math>\pm 0.5</math></td> <td><math>\pm 0.8</math></td> <td><math>\pm 1.2</math></td> <td><math>\pm 2</math></td> </tr> </table>		DIMENSIONS	< 6	> 6	> 30	> 120	> 315	> 1000	> 2000	GENERAL TOLERANCES	$\pm 0.1$	$\pm 0.2$	$\pm 0.3$	$\pm 0.5$	$\pm 0.8$	$\pm 1.2$	$\pm 2$	DWN _____	DRAWING NUMBER		
DIMENSIONS	< 6	> 6	> 30	> 120	> 315	> 1000	> 2000														
GENERAL TOLERANCES	$\pm 0.1$	$\pm 0.2$	$\pm 0.3$	$\pm 0.5$	$\pm 0.8$	$\pm 1.2$	$\pm 2$														
		CHKR _____	REVISION NUMBER																		

D

C

C

OF

SH

4

3

2