

## Overall Characteristics of 9 kW Class Helium Refrigerator for Experimental Fusion Device

This content has been downloaded from IOPscience. Please scroll down to see the full text.

2006 J. Phys.: Conf. Ser. 43 1063

(<http://iopscience.iop.org/1742-6596/43/1/260>)

View [the table of contents for this issue](#), or go to the [journal homepage](#) for more

Download details:

IP Address: 77.242.202.245

This content was downloaded on 21/01/2015 at 07:44

Please note that [terms and conditions apply](#).

# Overall Characteristics of 9 kW Class Helium Refrigerator for Experimental Fusion Device

S. Yamada<sup>1</sup>, S. Moriuchi<sup>1</sup>, R. Maekawa<sup>1</sup>, M. Noguchi<sup>2</sup>, K. Kuramochi<sup>2</sup>,  
T. Kishi<sup>2</sup> and T. Mito<sup>1</sup>

<sup>1</sup>National Institute for Fusion Science, 322-Oroshi, Toki, Gifu, 509-5292, Japan

<sup>2</sup>Mayekawa Mfg. Co., Ltd., 2-13-1 Botan, Koutouku, Tokyo, 135-8482, Japan

yamadas@LHD.nifs.ac.jp

**Abstract.** The cryogenic system for the experimental fusion device, LHD has an equivalent refrigeration capacity of 9.1 kW at 4.4 K, and will refrigerate all sets of superconducting coils, their supporting structures, superconducting bus-lines and current leads. Eight sets of oil injected screw-type compressors with the massflow rate of 1100 g/s are equipped. Massflow rate to coldbox was controlled to 700 g/s, and the other of 400 g/s was bypassed. To minimize the bypass flow and to reduce the power consumption, overall operating characteristics of the helium refrigerator were investigated in this report. A power consumption of 500 kW was decreased by reducing the massflow rate of 200 g/s in the bypass circuit.

## 1. Introduction

LHD is a large-scaled superconducting toroidal fusion device of heliotron type constructed at the National Institute for Fusion Science (NIFS) in Japan. The major objective of the LHD is to develop physics and technology of current-less, high temperature and steady-state plasmas confined in a heliotron type magnetic field configuration [1]. The body of the LHD consists of a pair of helical coils, three sets of poloidal coils and their supporting structures with total cold mass of 820 tons including the superconducting bus-lines with total length of 497 m. In order to attain the various magnetic field configurations, each helical coil is divided into three block coils that can be excited independently. The elongation or magnetic axis change of the plasma are adjusted by three pairs of the poloidal coils.

The construction of the LHD finished in February of 1998, and improved plasma confinement properties could be obtained through the first and second plasma experimental campaign in the first year. In a recent experiment, the electron and ion temperatures have reached up to 10 keV and steady-state discharge during 756 seconds was also obtained by the ion cyclotron resonance heating [2].

In LHD, steady-state cooling has been kept for more than five months in every experimental campaign, so that the power saving is one of the most desirable issues for the cryogenic system. To reduce the power consumption, unload operating characteristics of the helium circulating compressors were investigated in this paper. The relations among the massflow rate, stroke of the slide adjusting valves and power consumption were also studied.

## 2. Cryogenic system of the LHD

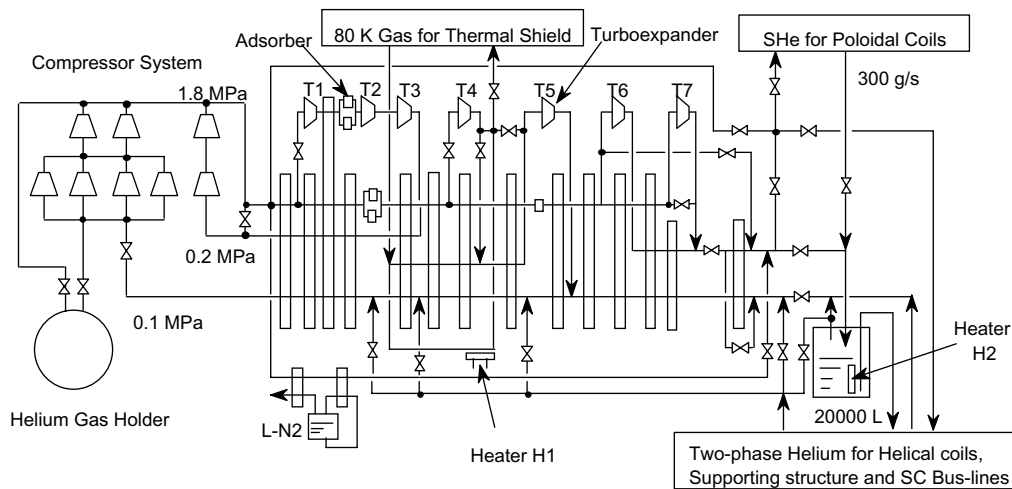

**Figure 1.** Helium liquefier-refrigerator system for the LHD.

**Table 1.** The hours of operation.

No. of Campaign (Fiscal year)	1st (1998)	2nd (1998)	3rd (1999)	4th (2000)	5th (2001)	6th (2002)	7th (2003)	8th (2004)
Compressor	2998	3148	5014	5054	5296	4920	5061	4869
Turbines	1943	2779	4297	3873	4104	3768	3767	3547

Figure 1 shows a flow diagram of a liquefier refrigerator system for the LHD. The system has a refrigeration capacity of 5.6 kW at 4.5 K and 20.6 kW at 40 - 80 K including 650 liters per hour liquefaction [3-4]. In a steady-state cooling, three turboexpanders T1 to T3 driven through middle pressure line of 0.2 MPa refrigerate the helium gas to liquid nitrogen temperature. The heat load of the radiation shield between 40 K to 80 K is covered by the flow exhausting from turbine T4 and coming back to T5. Two supercritical turbines T6 and T7 are equipped to improve the thermal efficiency of the J-T expansion line. A heater H1 is used to control the heat loads to T4 and T5 in constant. The heater H2 in the 20,000 liter liquid helium (LHe) reservoir is installed for adjusting the liquid level and the return cold to the coldbox in constant. Cryostable condition of the SC coils has been kept for more than five months in every experimental campaign. Operation history of the cryogenic system is summarized in Table 1.

Since the heat load and heat input into the cryogenic parts is not so large than that of the designed

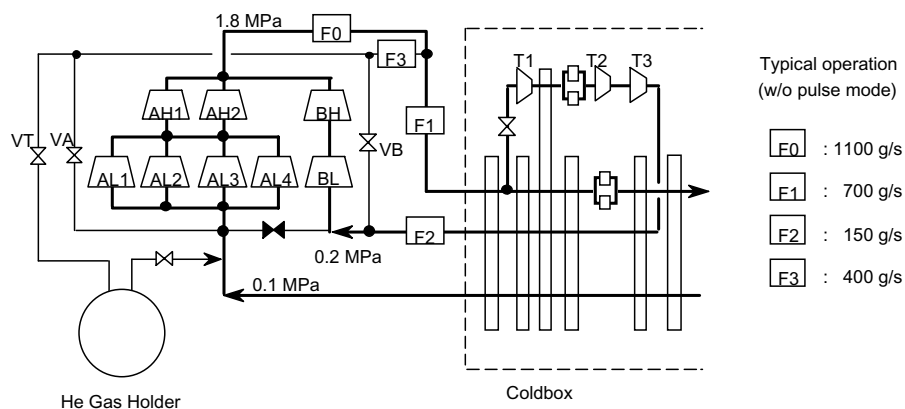

**Figure 2.** Arrangement of compressors and measuring points of massflow rates.

**Table 2.** Distributions of massflow rates in the coldbox

		C/B	T1-T3	T4 - T5	T6	T7
Designed process values	(g/s)	960	210	260	185	160
Typical operation w/o pulse mode	(g/s)	700	150	150	160	210

**Table 3.** Parameters of the compressors.

	unit	AL1	AL2	AL3	AL4	AH1	AH2	BL	BH
Diameter of male rotor	(mm)	320	320	320	250	250	250	250	250
Inlet pressure	(kPa)	101	101	101	101	397	397	203	520
Outlet pressure	(kPa)	412	412	412	412	1935	1935	535	1935
Rated Power	(kW)	400	400	400	210	740	740	270	330

values, the refrigeration power becomes superfluous. For the simplification of operation, refrigeration power is reduced as much as possible and excessive refrigerant is made to dissipate at the heaters in the 20,000 liter LHe reservoir and sub-cooling tanks of the SC bus lines [5]. Distribution of the massflow rate in the coldbox is listed in Table 2.

The system was made to the liquid nitrogen free for a steady-state operation, and high Carnot efficiency by using two different circulating lines for the compressors. Arrangement of compressors and typical operated values of massflow rates are shown in Figure 2. The plant has eight single-stage compressors of oil injection type. Compressor system has a discharge capacity of 1100 g/s for the electric power of 3.45 MW. Massflow rate of the main circulation is controlled to 700 g/s, and the other of 400 g/s was bypassed for the typical operation w/o pulse operation mode.

### 3. Unload characteristics of the compressor system

In long-term operation, reduction of power consumption will be one of the most important issues. To minimize the bypass flow and to reduce the power consumption, overall operating characteristics of the compressor system were investigated. In this test, the low pressure stage compressors of AL1 and AL2 were used. Main parameters of the compressors are listed in Table 3.

Following method was applied for the unload test of the compressors: 1) set the stroke of the valve of AL1 gradually from 100% to 5%, and come back to 100% again, then 2) set the stroke of the valve of AL4 gradually from 100% to 0%, and come back to 100% again. To avoid the perturbation for cooling the SC coil system of the LHD, we watched carefully whether the cooling conditions of the turbines in a cold box would change. The stroke of the valve and the massflow rate change are shown in Figure 3, and the relation of the electric power consumption and massflow rate change are shown in Figure 4. It was clearly seen that the massflow rate of a compressor responded with sufficient

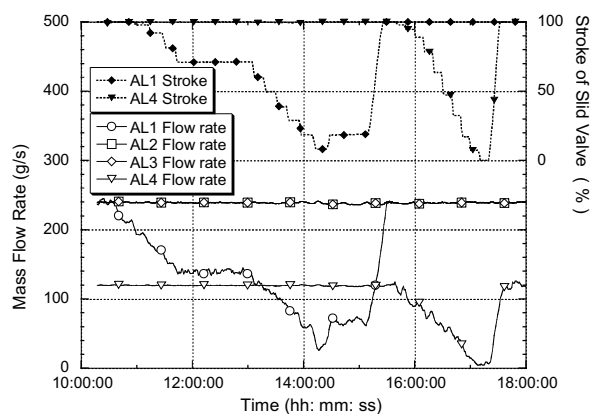
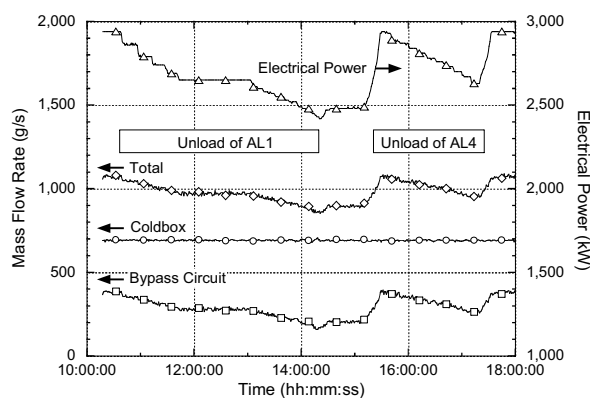
**Figure 3.** Typical waveforms of slide valve stroke and massflow rate change.**Figure 4.** Typical waveforms of electric power and massflow rates.

**Table 4.** Massflow rate of the compressors.

	unit	AL1	AL2	AL3	AL4	AH1	AH2	BL	BH
Process values	(g/s)	215	215	215	105	375	375	210	210
Measured value	(g/s)	240	240	240	120	420	420	260	260

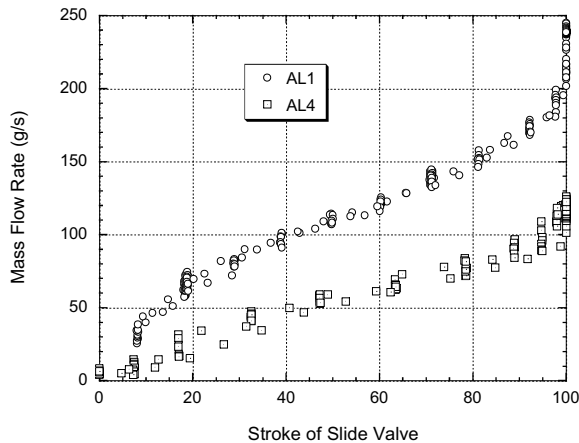
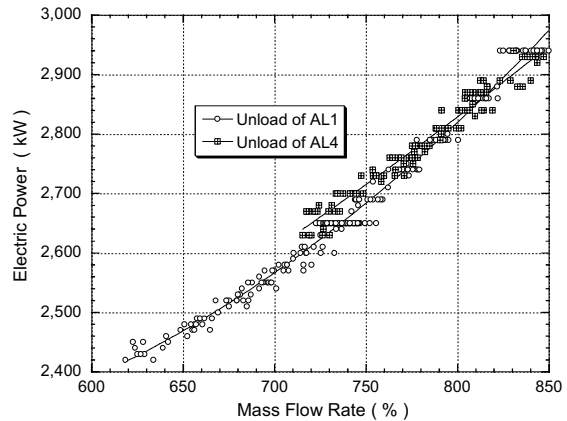
**Figure 5.** Measured massflow rate as a function of the slide valve stroke.**Figure 6.** Measured electric power as a function of the massflow rate.

accuracy to a gradual change of a stroke. The maximum flow rate of the compressors, AL1, AL2, and AL3 were 240 g/s. The maximum flow rate of AL4 was 120 g/s. The test results are summarized in Table 4. It was confirmed that all compressor units have the capacity margin of more than 10 %.

Figure 5 gives the relation between the stroke of a slide valve and the flow rate. In a case of screw compressor, a flow rate of discharged gas changes sensitively for the slight movement of a valve stroke. When the stroke of a slide valve changes 5 % from 95%, a flow rate increases almost 20%. Therefore, it may be better to prepare the limiting circuit of fixation, in order to operate stably in a full loading point. Figure 6 shows the relation between the electric power consumption and massflow rate. The experimental result of the power consumption to a massflow rate was almost the same for the compressors AL1 and AL4. The slight difference of inclination in a Figure may originate in the difference of the load efficiency of the induction motors. It was confirmed that reduction of 200g/s was equal to a reduction of 500 kW of power in a compressor system.

#### 4. Conclusion

Overall operating characteristics of the helium circulating compressors were investigated in this paper. The results are concluded as follows; (1) it was confirmed that all compressor units have the capacity margin of more than 10 %, (2) a massflow rate of a compressor responded with sufficient accuracy to a gradual change of a stroke, and (3) a power consumption of 500 kW was decreased by reducing the massflow rate of 200 g/s in the bypass circuit.

#### Acknowledgements

This work is supported by the collaboration between NIFS and Mayekawa Mfg. Co., Ltd as well as a grant from NIFS with ULAA104. The authors would like to express their appreciation to the operators of the LHD cryogenic system for their kind advices and encouragements.

#### References

- [1] Iiyoshi, A et al.: Nuclear Fusion, 39 (1999) 1245-1256.
- [2] Motojima, O. et al.: 20th IAEA Fusion Energy Conference (2004) OV/1-4.
- [3] Satoh, S. et al.: Advances in Cryogenic Engineering, Vol. 42 (1996) pp.727-735.

- [4] Yamada, S. et al.: Proc. of 16th ICEC, Kitakyuushu, Part 1 (1997) pp.83-86.
- [5] Yamada, S. et al.: IEEE Trans Applied Supercond. 12 (2002) pp.1328-131.