

Introduction to Cryogenics

Carolin Heidt
KSETA- Workshop Freudenstadt 2013

INSTITUTE FOR TECHNICAL PHYSICS,
INSTITUTE FOR TECHNICAL THERMODYNAMICS AND REFRIGERATION



Source:
Cern Website

Outline

- Introduction
- Cold production
- Cryogenic Properties
 - Cryogenic fluids
 - Material Properties
- Cryostats
 - Dewar vessel
 - Thermal Insulation
 - Cern
 - Temperature measurement
 - Flow measurement
 - Safety



Source:
Cern Website

Introduction

- Cryogenics -> Greek: production of freezing cold
- Cryogenics -> Refrigeration at $T < 120\text{K}$ (definition since 1971)
- Cryogenics \leftrightarrow Cryonics = preservation of the human body in LN₂ after death



Source:
http://www.dailygalaxy.com/my_weblog/2007/10/experimental-tr.html



Source:
http://theinfosphere.org/images/cache/enwiki/f/fd/Cryogenic_Freezing_Chamber.html

Introduction

■ Applications:

- Condensation & liquefaction of gases
 - Air separation
 - Transport
 - Storage
- Reduction of thermal noise and excitation
 - Particle accelerators
 - Particle detectors
- Others
 - Food Freezing
 - Space flight technology
 - LH2 technology
 - Medical applications

Cold production (Basic)

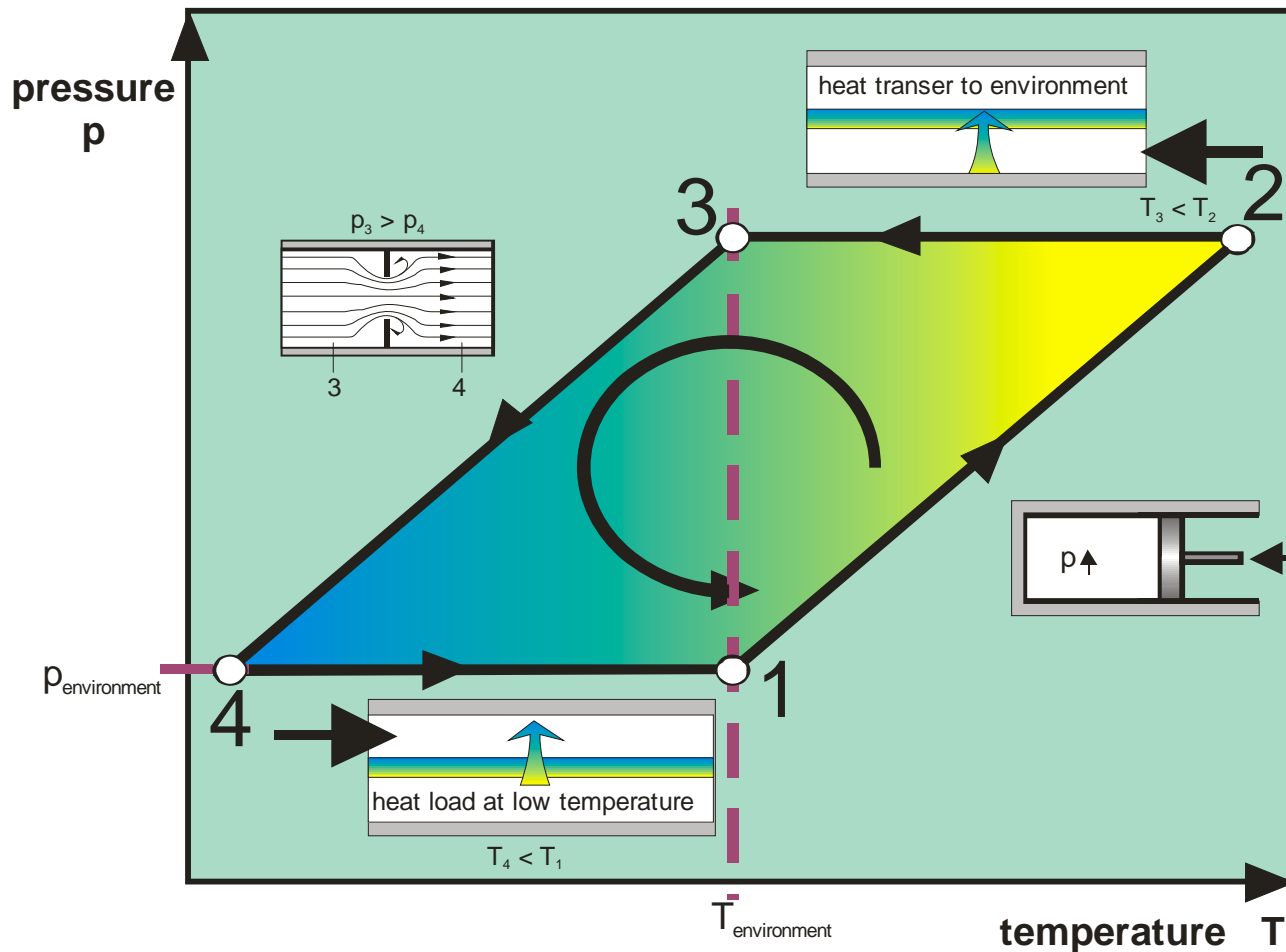

- Basic principle:
 - Compression
 - Heat transfer to ambient
 - Throttling/expansion
 - Heat load at low temperature

Source:
 H. Neumann, ITEP, KIT, 2013 ESAS Summer School

Cold production (Refrigeration Cycles)

■ Joule-Thompson-Process (Linde)

- Simple, reliable
- Low efficiency

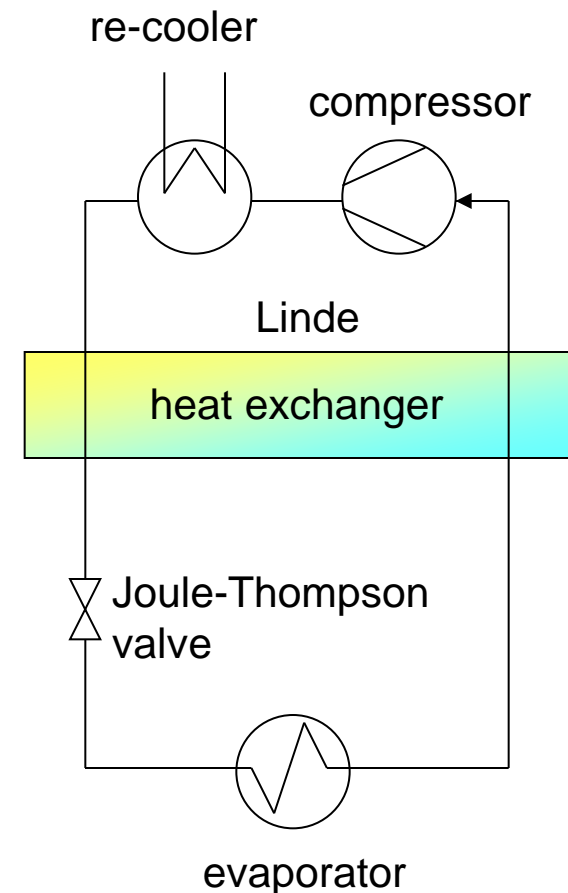

Source:
H. Neumann, ITEP, KIT, 2013 ESAS
Summer School

Cold production (Refrigeration Cycles)

■ Claude-Process

- Higher efficiency
 - Expansion of partial current for extra cooling
- Less reliable

■ Stirling Process

- Compact
- No liquefaction

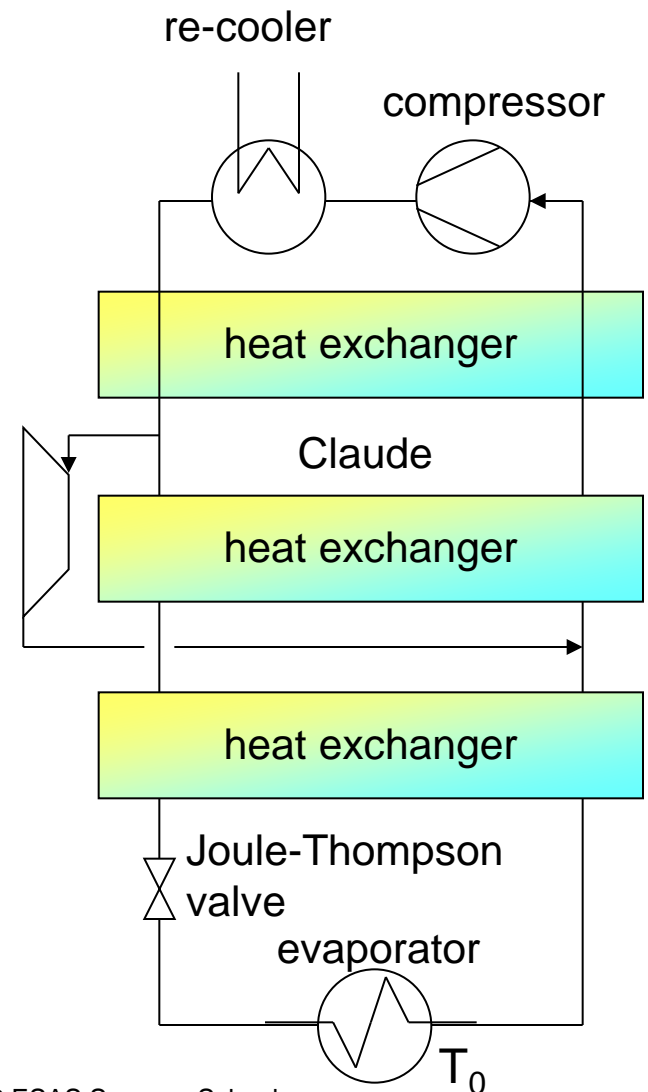

Source:
 H. Neumann, ITEP, KIT, 2013 ESAS Summer School

Cold production (Refrigeration Cycles)

■ Example: 2kW helium liquefier at ITEP

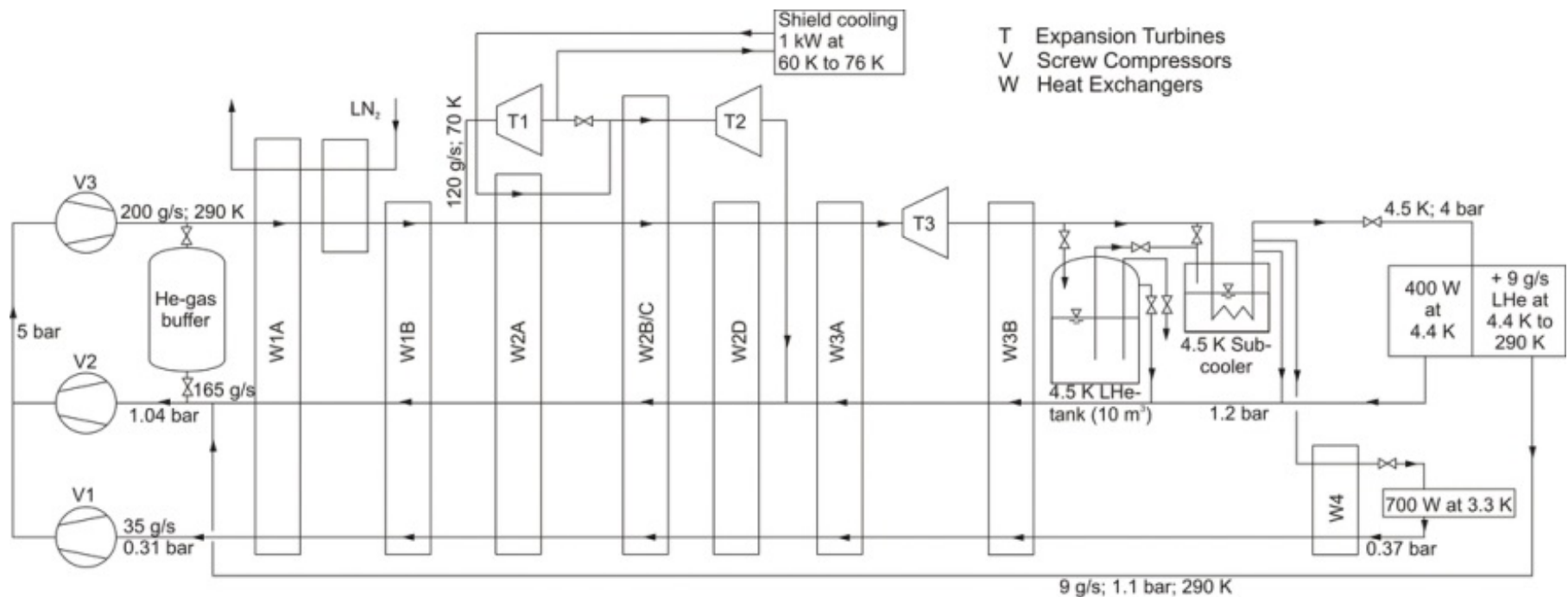

Source:
ITEP Homepage

Cryogenic fluids

■ Vapor-pressure curves

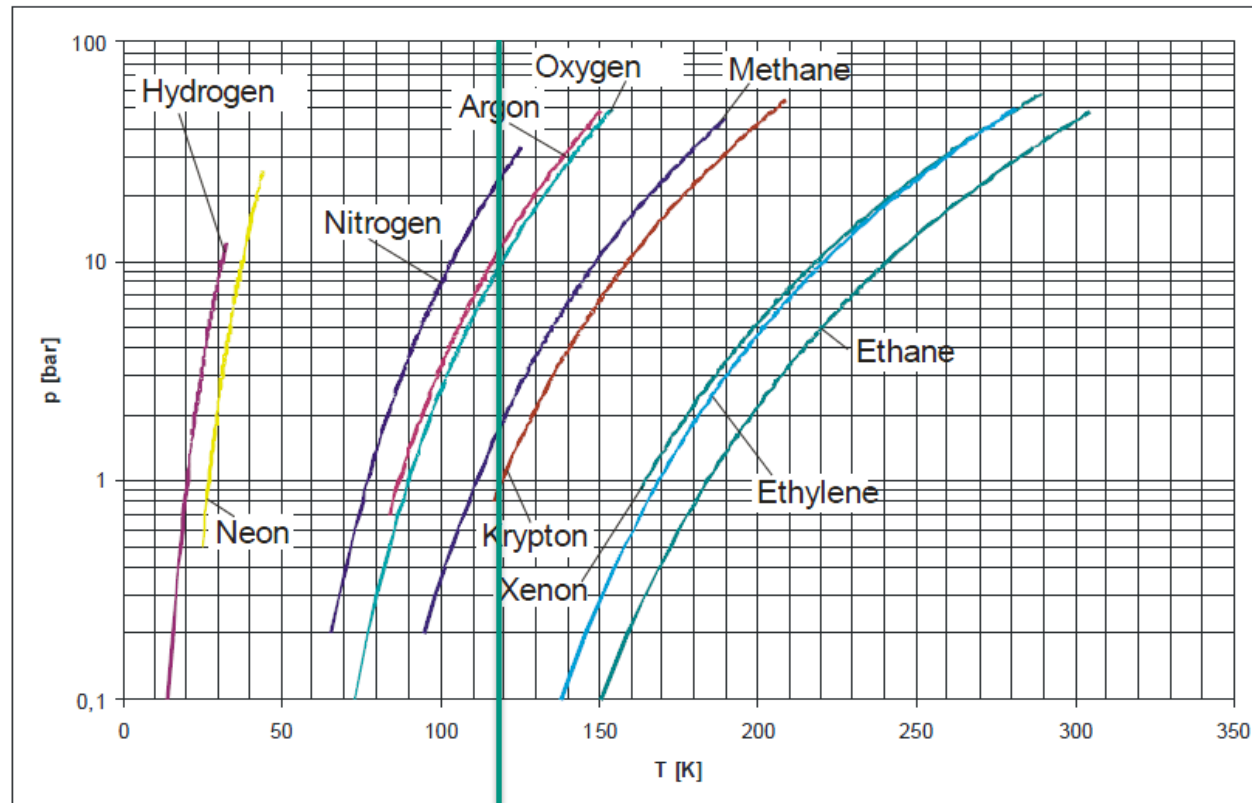

Cryogenics

120 K

Refrigeration

Source:
 H. Neumann, ITEP, KIT, 2013 ESAS
 Summer School

Cryogenic fluids (Helium)

■ Specifics of helium

■ λ -line separates

■ LHe I

■ LHe II (superfluid)

- Very high thermal conductivity
- No boiling
- Onnes-effect

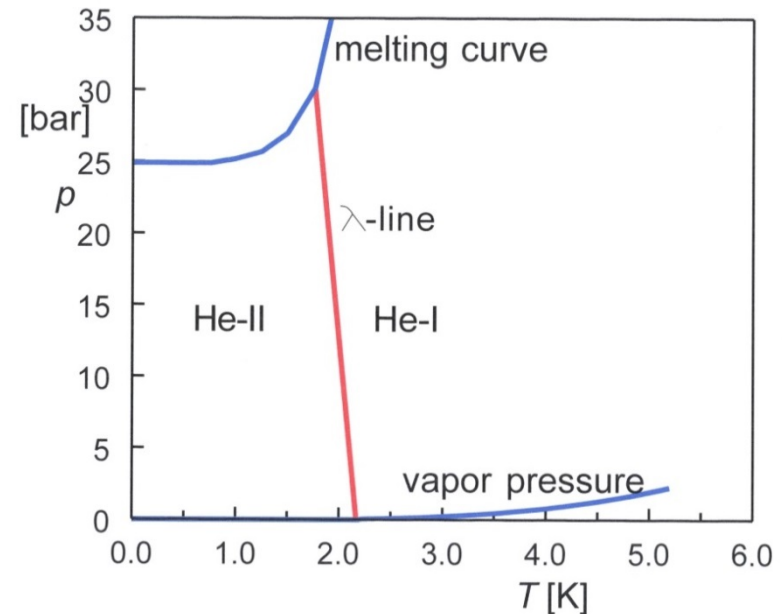

Source:
Wikipedia „Helium“

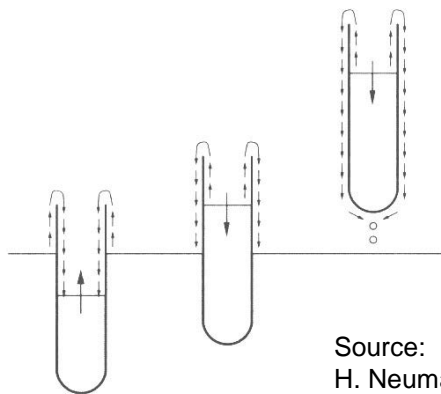

Source:
H. Neumann, ITEP, KIT, 2013 ESAS
Summer School

Material Properties

■ To take into account:

- Heat conductance
 - varies with decrease in T
- Thermal contraction
 - different contractions of different materials
- Mechanical characteristics
 - elastic limit and modulus increase ☺
 - ductility and plasticity decrease dramatically -> brittleness ☹
- Consult AD 2000-W10 for materials at cryogenic temperatures



Source:
K.Weiss, ITEP meeting 2012

Cryostats (Layout)

- example: LN₂-vessel with integrated pressure generation

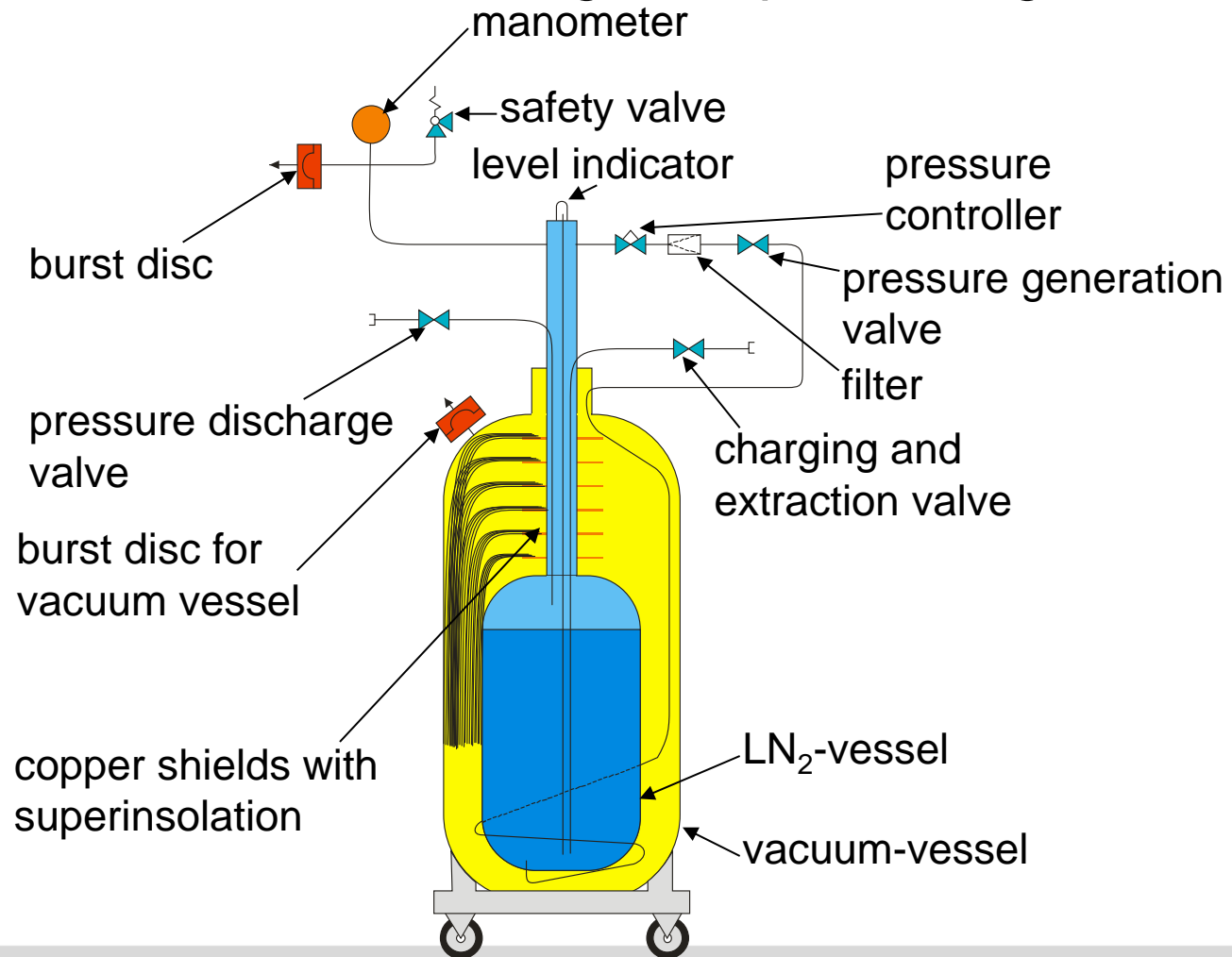

Cryostats (Insulation)

- Types of thermal insulation
 - Powders, foams, fibreglas,...
 - Vacuum Insulation

- MLI (Multi-Layer-Insulation) or SI (Super-Insulation)
 - high vacuum (prevents convection)
 - reflecting layers, e.g. Al foil (reduce radiation)
 - spacer elements, e.g. glas fibre (have low heat conductivity)



Source: V. Chrz
<http://indico.cern.ch/getFile.py/access?sessionId=3&resId=0&materialId=0&confId=90787>

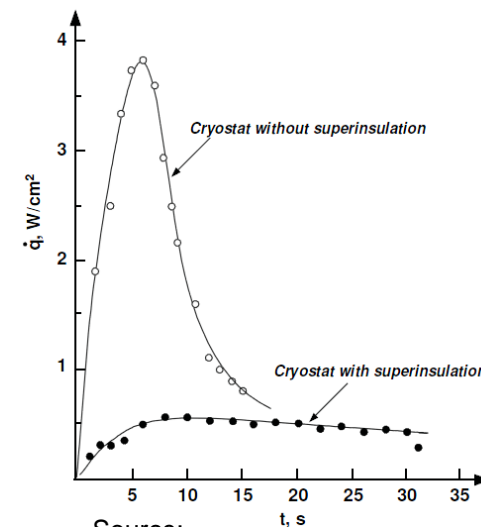

Source:
 Lehmann/Zahn, 1978, Proc. CEC

Cryostats (CERN)

- Example: CERN, the largest cryogenic system in the world
 - 36,000 t of SC magnets (NbTi wires) operate at 1.9 K
 - Need of 136 t of helium (superfluid below 2.17K, very high thermal conductivity -> efficient heat conductor)
 - Closed LHe circuit, 27 km long
 - Entire cooling process takes weeks to complete



Source: Cern website
<http://home.web.cern.ch/about/engineering/cryogenics-low-temperatures-high-performance>

Cryostats (CERN)



Compressor unit of the 4.5 K refrigerator

Source: Cerncourier

<http://cerncourier.com/cws/article/cern/54382>

- 8 units in the complete system
- Each cryoplant consists of 3 stages
 1. RT- \rightarrow 80 K
using 10,000 t LN₂ in HX (600 kW)
 2. 80 K \rightarrow 4.5 K
using refrigerator with cooling capacity of 18 kW at 4.5 K
 3. 4.5 K \rightarrow 1.9 K
using refrigerator with cooling capacity of 2.4 kW at 1.8 K

Cryostats (Temperature Measurement)

■ temperature measurement

■ low temperature sensors (secondary temperature sensors)

■ *resistive sensors*

■ *negative temperature coefficient (NTC)*

- carbon - glas sensor (CG)
- Cernox (CX1050)
- carbon sensor (Allen Bradley C100)
- germanium (Ge)
- carbon composite (TVO)

■ *positive temperature coefficient (PTC)*

- platinum sensor (Pt100)
- rhodium - ferric - sensor (RhFe)

diodes

Si - diodes
GaAlAs - diodes

others

thermocouple (CuKo)
CLTS (Cryogenic Linear Temperature Sensor)
capacity thermometers

(by M. Süßer)

Cryostats (Temperature Measurement)

■ Characteristic curves of resistive sensors

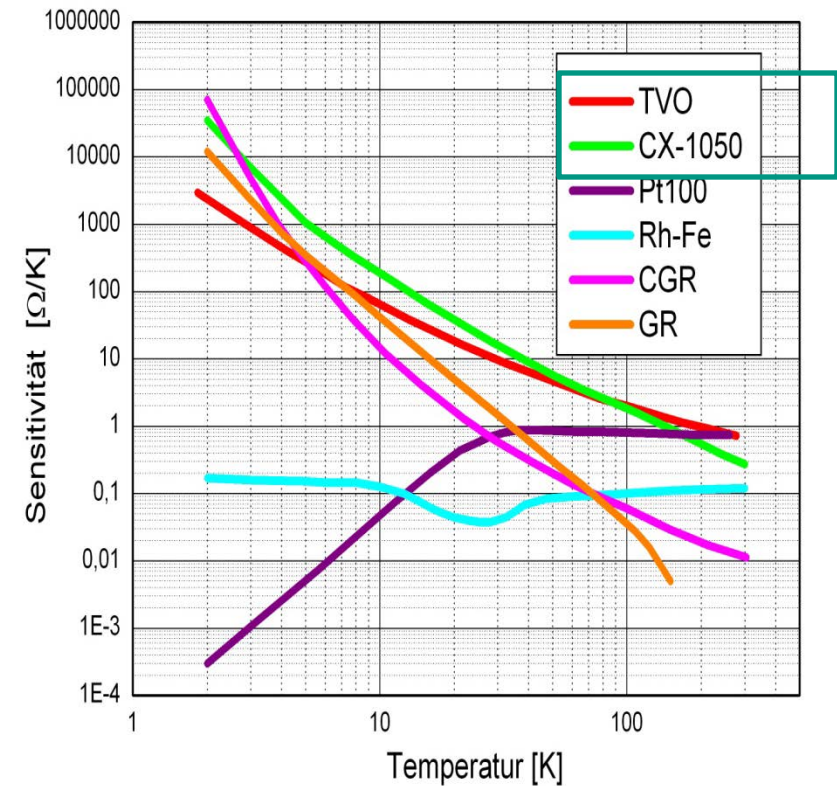
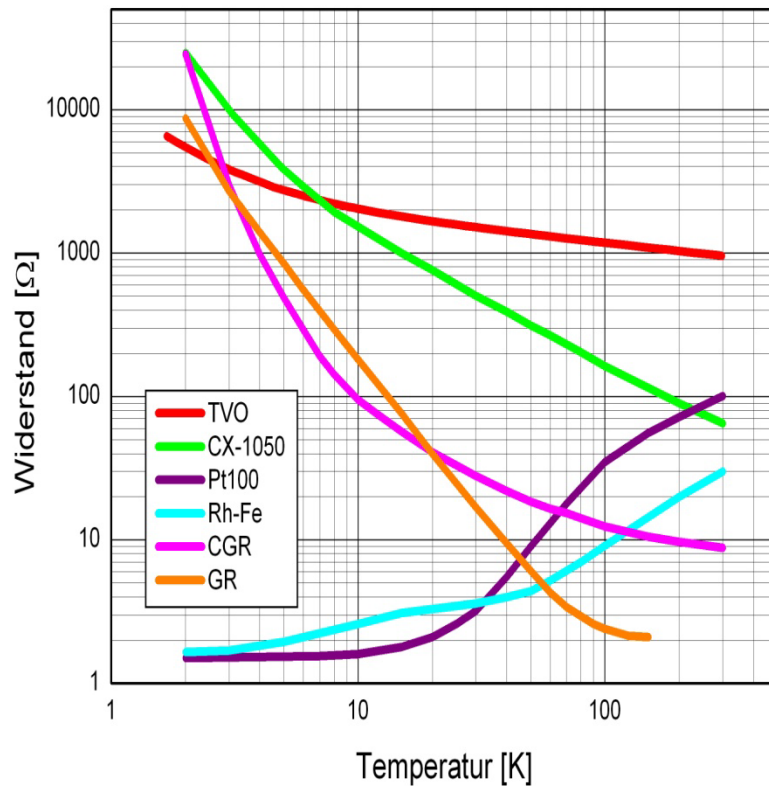

Source: M.Süßer, Einführung in die Tieftemperaturmesstechnik

Cryostats (Temperature Measurement)

■ TVO

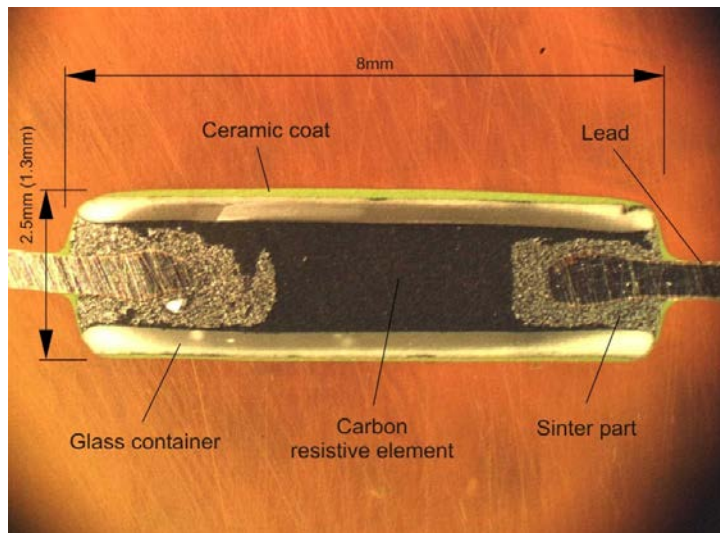

- Carbon- Al_2O_3 Compound
- Calibration at ITEP
- Costs ~ 400 €
- Able to work under high pressure and stress

■ Cernox

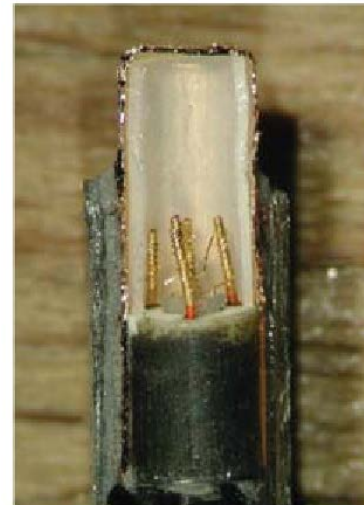

- Zirconium-Nitride-film on saphir body
- Lakeshore
- Costs ~650€

Source: M.Süßer, Einführung in die Tieftemperaturmesstechnik

Cryostats (Mass flow measurement)

■ Mass flow measurement

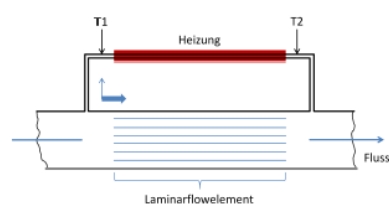
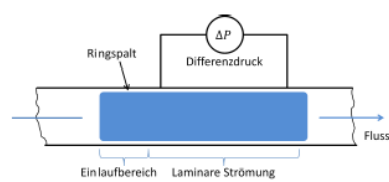
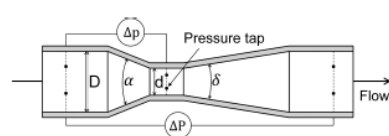
	System	Einsatzgebiet	Messgröße
	Thermischer Durchflussmesser	Prozesssteuerung	$q \sim \Delta T$
	Laminarflowelement	Präzisionsmessung	$q \sim \Delta P$
	Venturi-Rohr	Messung bei flüssig Helium Temperatur	$q \sim \sqrt{\Delta p}$

Source: M.Schrank, DKV-Tagung 2012

Cryostats (Safety)

- Safety standards:
 - DIN EN 13648
 - EN ISO 4126
 - AD 2000
 - To come: DIN SPEC 4683 „Überdruck-Absicherung von Helium-Kryostaten“



Sources

- Information on Cryogenics:
 - H. Neumann, ITEP, KIT, Talk at 2013 ESAS International Summer School on Materials and Applications of Superconductivity, 1st August 2013
 - M.Schrank, Introduction to cryogenics, Vortrag beim Young Scientists Workshop 2013, Kristberg
- Information on Dewar vessels and MLI:
 - V. Chrz, Chart Ferox, <http://indico.cern.ch/getFile.py/access?sessionId=3&resId=0&materialId=0&confId=90787> Information on Cryogenic Measurement
- Information on CERN Cryogenics :
 - <http://cerncourier.com/cws/article/cern/54382>
 - <http://home.web.cern.ch/about/engineering/cryogenics-low-temperatures-high-performance>
- Information on Cryogenic Measurement
 - M. Süßer, Einführung in die Tieftemperaturmesstechnik, Interner Bericht FE.5130.0013.0012/N
 - M. Schrank, Gasdurchflussmessung in der Kryotechnik, Vortrag bei der DKV-Tagung 2012, Würzburg
- Information on Helium Cryogenics Safety
 - W. Lehmann/ G. Zahn, Safety aspects for Lhe cryostats and Lhe transport cptainers, Proc. ICEC, London, 1978, Vol. VII, 569-579

Thank you for your Attention



Great thanks to H. Neumann, M. Süßer and M. Schrank for their contribution to this talk